

## DUAL ART™ OPERATING INSTRUCTIONS

Your Xylem Dual Art faucet was specifically designed for use with multiple types, styles and sizes of lavatory bowls. To properly set up your new Dual Art faucet please follow the following simple instructions:

- Loosen the **KNURLED NUT (1)** and adjust the upper arm to desired height for optimal clearance and expected water stream placement
- Hand tighten **KNURLED NUT (1)**
- Turn on water by pushing back on the single lever handle for maximum flow (note that this "short throw" handle movement is limited for use when faucet is placed close to the wall)
- With water flowing, adjust the spout assembly by rotating the **SPOUT END (4)** until water stream does not splash out over the bowl edge
- If needed, readjust the upper arm by loosening the upper arm **KNURLED NUT (1)** and repositioning arm until the desired water stream is attained
- Once set, turn off water and tighten **SET SCREWS (3)** on the back of the upper arm which will keep the arm in place permanently or until set screw is loosened again
- **SET SCREW (2)** limits the arm travel but can be tightened to help secure arm once properly positioned

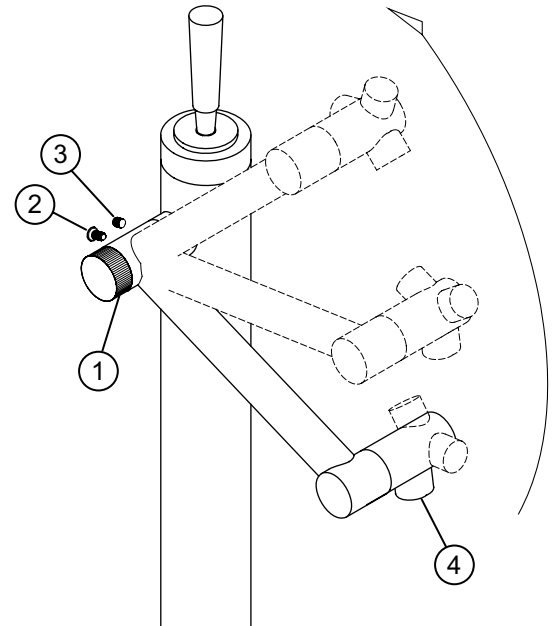

You are now ready to operate and enjoy your innovative Dual Art faucet!

## SUGGESTED TOOLS AND MATERIALS

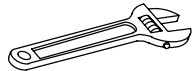

Adjustable Wrench



Teflon Tape



Hex Wrench (supplied)



Channel Lock

## BEFORE YOU BEGIN

- Turn off the main water supply
- Observe all local plumbing and building codes
- Deck hole Diameter: 1-1/4" to 1-3/8" diameter
- Maximum deck thickness is 3"
- This lavatory faucet comes completely assembled and water tested
- 15" braided stainless steel supply lines included with 3/8" compression inlets

## INSTALL THE LAVATORY FAUCET

**Important!** Use care when installing the lavatory faucet to avoid scratching the finish.

- Unscrew **NUTS (10)**, **THRUST WASHER (9)** and **RUBBER GASKET (8)** from **FAUCET BODY (7)**
- Feed the **FAUCET SUPPLY LINES (4)** through the countertop hole
- Seat **O-RING (5)** and **BASE ESCUTCHEON (6)** into under side of **FAUCET BODY (7)**
- From below, install **RUBBER GASKET (8)**, **THRUST WASHER (9)** and thread on **HOLD-DOWN NUTS (10)**
- Before final tightening, adjust faucet so that it is centered and positioned correctly then tighten **HOLD-DOWN NUTS (10)**

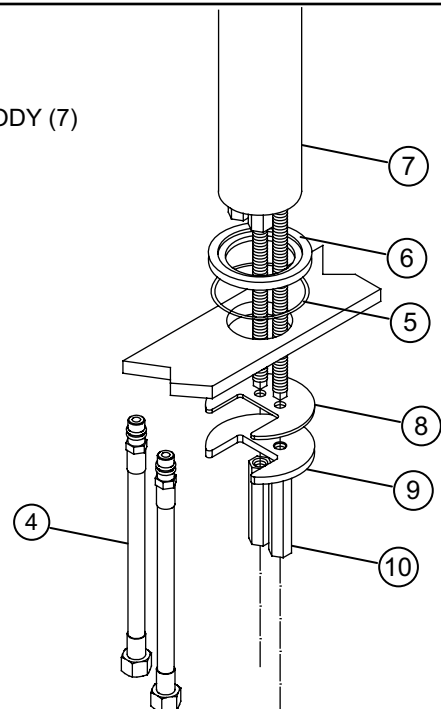

## WATER SUPPLY CONNECTIONS

**Important!** If **SUPPLY LINES** are too long, loop them to avoid kinking. If additional supply length is required, installer must purchase additional parts separately.

- Connect the **FAUCET SUPPLY LINES (4)** directly to the existing wall / floor supplies  
 Connect Left supply to **HOT** (Marked with a Red Band) and Right supply to **COLD**
- Tighten the 9/16" compression nuts with small crescent wrench and do not over tighten as this may strip the threads

## PAGE 2

### TEST INSTALLED FAUCET

- Unscrew CAP BOLT (11) with AERATOR INSERT (12) and GASKET (13).
- With handle in OFF position, turn on water supplies and check all connections for leaks. Turn ON faucet for two minutes to flush water lines thoroughly. Debris in the water can damage the CERAMIC CARTRIDGE (14) causing it to leak.
- Replace CAP BOLT (11) with AERATOR INSERT (12) and GASKET (13).

### SERVICE

**Caution:** Turn off hot and cold water supplies before beginning.

- To remove and clean or replace cartridge:
- Unscrew the HANDLE (15) and ESCUTCHEON (16)
- Unscrew BRASS DOME CAP (17) and pull up on CERAMIC CARTRIDGE (14)
- Inspect CERAMIC CARTRIDGE (14) for debris and clean if necessary.
- Reinstall CERAMIC CARTRIDGE (14), BRASS DOME CAP (17), ESCUTCHEON (16) and HANDLE (15)

### CARE INSTRUCTIONS

To keep your new faucet looking new, please follow these simple care instructions

- DO:** Simply rinse the faucet clean with clean water and mild soap  
Dry the faucet with a soft cotton cloth
- DON'T:** Do not use any abrasive cleaners, cloths or paper towels.  
Do not use any cleaning agents containing acids, polish abrasives or harsh cleaner or soap

Regular and routine cleaning will reduce the need for heavy cleaning and polishing.

